



# DTA

Damen Technical Agencies



## Hydraulic Hybrid Pumps T6H20B, T6H20C

Denison Vane Technology, variable and fixed displacement

### Hydraulic Pumps

- Hydraulic Motors
- Hydraulic Valves
- Hydraulic Cylinders
- Hydraulic Filtration
- Hydraulic Accumulators



ENGINEERING YOUR SUCCESS.

## We are doing our parts to keep you moving!

DTA your 1 Stop Shop for Hydraulics, Pneumatics and Power Transmissions.

# DECLARATION OF CONFORMITY

DTA Hydraulics is a tradename of Damen Technical Agencies BV, supplying hydraulic parts to various industries since 1990. As a Certified Distributor Hydraulics by Parker Hannifin and Authorized Denison Vane Pump Assembler, we guarantee the use of original parts and components. As such we provide you with vane pumps of the same level of quality and warranty conditions as the factory does.

We highly recommend to **use genuine Denison Hydraulics spare parts only** in order to ensure smooth operation and longer service life. Spare parts that we have on stock include pump cartridge kits, shaft and bearing assemblies, seal kits and non-wearing parts of both the T6 and T7 series vane pumps.



**ALL VANE PUMPS SUPPLIED OR REPAIRED BY  
DTA HYDRAULICS HAVE BEEN ASSEMBLED ACCORDING  
TO THE LATEST FACTORY SPECIFICATIONS WITH  
BRAND NEW AND GENUINE DENISON HYDRAULICS PARTS**

We are able to provide you a large variety of options of the original Parker Denison single, double, and triple vane pumps. We can build any customized vane pump from our stock of genuine parts. You can now easily configure that vane pump yourself with the Denison Hydraulics Vane Pump Configurator.

[vanepump.eu/vanepumps](http://vanepump.eu/vanepumps)

Use advanced search to filter results based on configurable options and select any of the 25,000 vane pumps that are listed in our online catalogue. Most of the models are available from stock and ready for shipment to any place in the world instantly. We can supply **Any part, Anytime, Anywhere!**



Model No. T6H20B - B08 - 1 L 1 B - 2 F 0 M 0 - 00 - ....  
T6H20C - \*12 - 1 L 1 C - 2 F 0 M 0 - 00 - ....

**Series and capacity P1**  
(rotating group)  
42,9 ml/rev.

**Cam ring P2**  
(Delivery at 0 bar & 1500 r.p.m.)

T6H20B	T6H20C
B02 = 8,7 l/min	*03 = 16,2 l/min
B03 = 14,7 l/min	*05 = 25,8 l/min
B04 = 19,2 l/min	*06 = 31,9 l/min
B05 = 23,9 l/min	*08 = 39,6 l/min
B06 = 29,7 l/min	*10 = 51,1 l/min
B07 = 33,7 l/min	*12 = 55,6 l/min
B08 = 37,4 l/min	*14 = 69,0 l/min
B10 = 47,7 l/min	*17 = 87,4 l/min
B12 = 61,5 l/min	*20 = 95,7 l/min
B15 = 75,0 l/min	*22 = 105,4 l/min
	*25 = 118,9 l/min
	*28 = 133,2 l/min
	*31 = 150,0 l/min

**Type of shaft**  
1 = keyed (SAE BB) 3 = splined (SAE C)  
4 = splined (SAE BB) 5 = keyed (SAE C)

**Direct. of rotation (view on shaft end)**  
R = clockwise  
L = counter-clockwise

**Seal class**  
1 = S1 BUNA N  
5 = S5 VITON®

**Design letter**  
B = T6H20B  
C = T6H20C

**Modification**

**Porting combination**  
Depend on the rotation - See page 26

**Variables port**

	Dia	Code
P2	1"	0
P2	3/4"	1

**Variables flanges connections**

4 bolts SAE flange (J518c)  
0 = UNC thread  
M = metric thread)

**Control accessories**

0 = Maxi flow  
9 = 90% maxi flow  
8 = 80% maxi flow  
7 = 70% maxi flow  
6 = 60% maxi flow  
5 = 50% maxi flow

**Control**

C = Compensator  
F = RC pilot operated compensator  
L = RC pilot operated compensator "load sensing"  
X\* = RC pilot operated compensator with vent valve 24 VDC  
\* Use with external drain only

**Connection (drain + vent.)**

0 = ext. drain + UNF thread  
2 = ext. drain + BSPP thread  
3 = int. drain + UNF thread  
4 = int. drain + BSPP thread

\* = 0 = Indust. uni-rotational / B = Indust. bi-rotational / M = Mobile bi-rotational

**OPERATING CHARACTERISTICS - TYPICAL [24 cSt]**

Pressure port	Series	Volumetric Displacement Vi	Flow Q [l/min], n = 1500 RPM				Input power P [kW], n = 1500 RPM			
			p = 0 bar	p = 140 bar		p = 300 bar	p = 7 bar	p = 140 bar	p = 300 bar	
P2 T6H20B	B02	5,8 ml/rev	8,7	7,0		5,1	0,5	2,6	5,1	
	B03	9,8 ml/rev	14,7	13,0		11,1	0,6	4,0	8,1	
	B04	12,8 ml/rev	19,2	17,5		15,6	0,6	5,0	10,4	
	B05	15,9 ml/rev	23,9	22,2		20,2	0,7	6,1	12,7	
	B06	19,8 ml/rev	29,7	28,0		26,1	0,7	7,5	15,6	
	B07	22,5 ml/rev	33,7	32,0		30,2	0,8	8,5	17,6	
	B08	24,9 ml/rev	37,4	35,7		33,7	0,8	9,3	19,5	
	B10	31,8 ml/rev	47,7	46,0		44,1	0,9	11,7	24,6	
	B12	41,0 ml/rev	61,5	59,8		57,9	1,2	14,9	31,5	
B15	50,0 ml/rev	75,0	73,3		71,6 <sup>1)</sup>	1,3	18,1	35,7 <sup>1)</sup>		
			p = 0 bar	p = 140 bar		p = 240 bar	p = 7 bar	p = 140 bar	p = 240 bar	
				Indust.	Mobile	Indust.	Mobile			
P2 T6H20C	*03	10,8 ml/rev	16,2	11,2	10,7	7,7	-	1,3	5,3	8,4
	*05	17,2 ml/rev	25,8	20,8	20,3	17,3	15,8	1,4	7,5	12,2
	*06	21,3 ml/rev	31,9	26,9	26,4	23,4	21,9	1,5	8,9	14,7
	*08	26,4 ml/rev	39,6	34,6	34,1	31,1	29,6	1,6	10,7	17,7
	*10	34,1 ml/rev	51,1	46,1	45,6	42,6	41,1	1,7	13,4	22,3
	*12	37,1 ml/rev	55,6	50,6	50,1	47,1	45,6	1,7	14,4	24,1
	*14	46,0 ml/rev	69,0	64,0	63,5	60,5	59,0	1,9	17,6	29,5
	*17	58,3 ml/rev	87,4	82,4	81,9	78,9	77,4	2,1	21,9	36,9
	*20	63,8 ml/rev	95,7	90,7	90,2	87,2	85,7	2,2	23,8	40,2
	*22	70,3 ml/rev	105,4	100,4	99,9	96,9	95,4	2,3	26,1	44,1
	*25	79,3 ml/rev	118,9	113,9	113,4	110,4	108,9	2,5	29,2	49,5
*28	88,8 ml/rev	133,2	128,2	127,7	125,8 <sup>2)</sup>	124,5 <sup>2)</sup>	2,8	32,7	48,5 <sup>2)</sup>	
*31	100,0 ml/rev	150,0	145,0	144,5	142,6 <sup>2)</sup>	141,3 <sup>2)</sup>	2,8	36,5	54,4 <sup>2)</sup>	

<sup>1)</sup> B15 = 280 bar max. int.      <sup>2)</sup> 028 - 031 = 210 bar max. int.  
- Not to use because internal leakage greater than 50% theoretical flow.

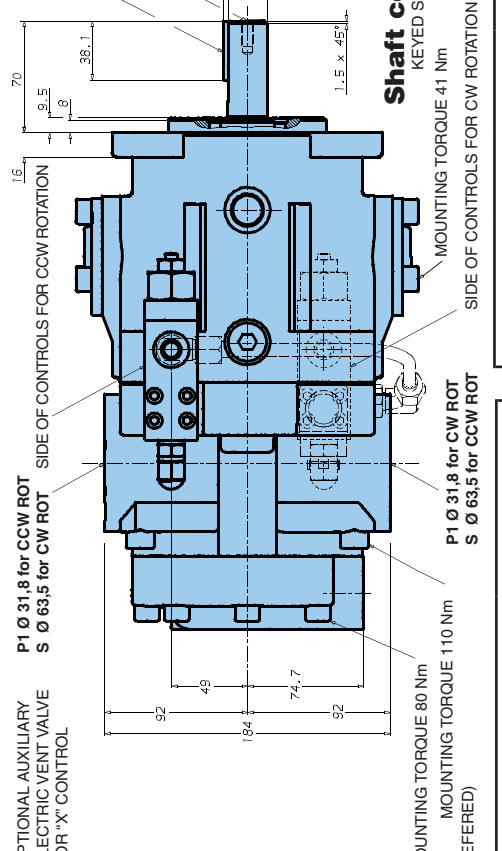
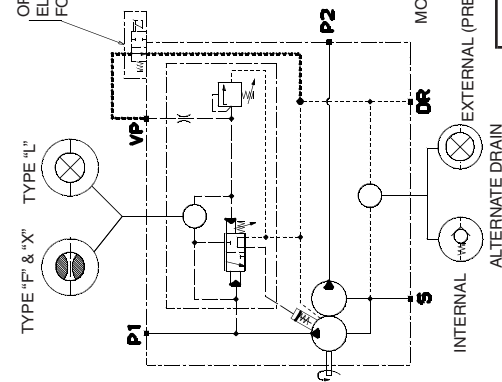
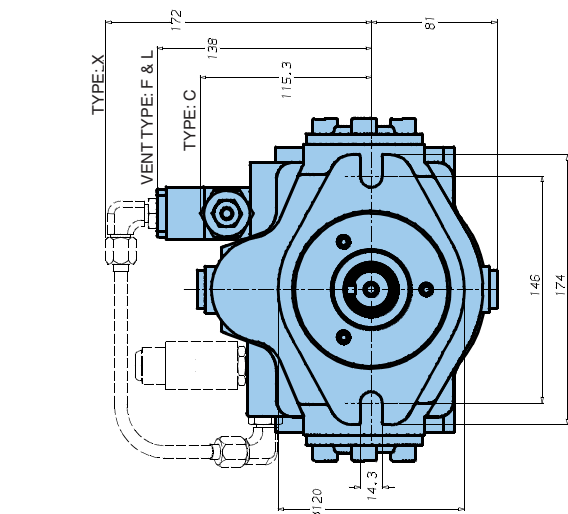
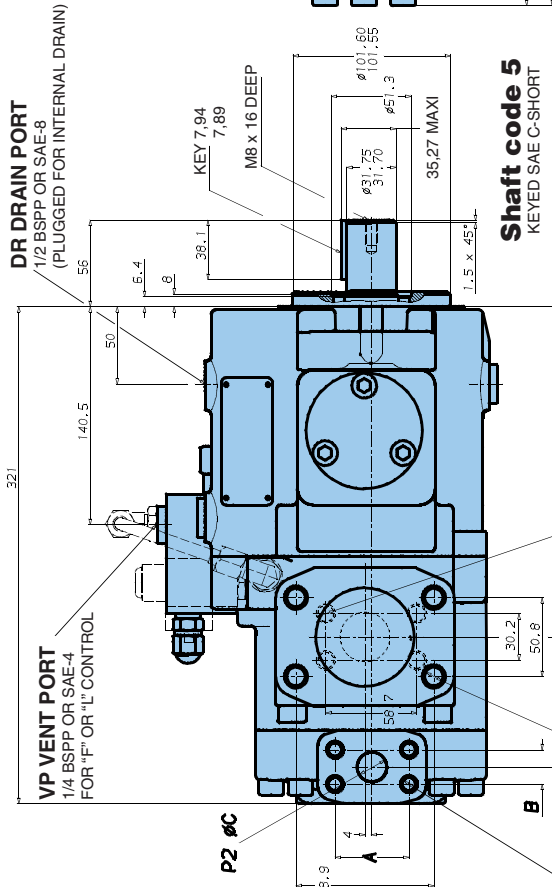
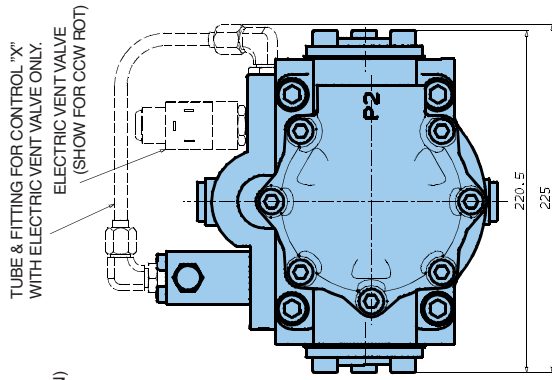

Variable port				
Port	Code	A	B	Ø C
P2	0	52,4	26,2	25,4
P2	1	47,7	22,4	19,0

Shaft torque limits [m/rev. x bar]	
Shaft	V1 x p max.
1	21420
4	32670

**HYDRAULIC CIRCUIT**  
(SHOWED FOR "F", "L" OR "X" CONTROL)



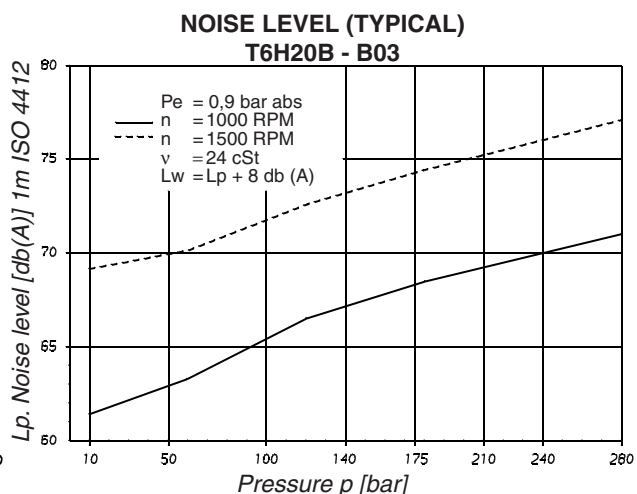
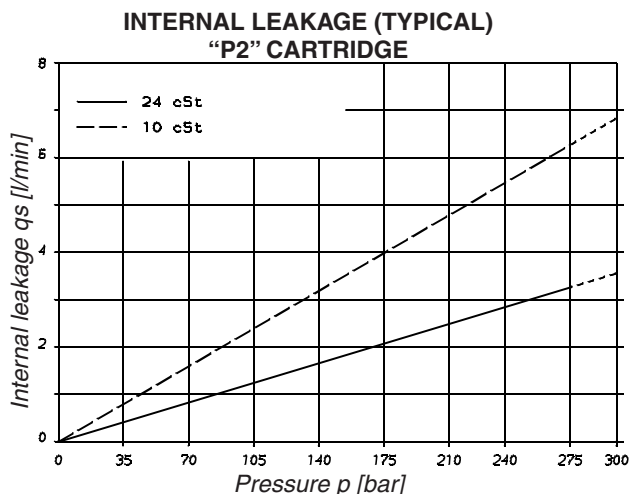

Do not operate pump more than 5 seconds at any speed or viscosity if internal leakage is higher than 50% of theoretical flow.

Noise level is given with each cartridge discharging at the pressure noted on the curve (P1 full flow).

**HYDROMECHANICAL POWER LOSS (TYPICAL)  
 "P2" CARTRIDGE**

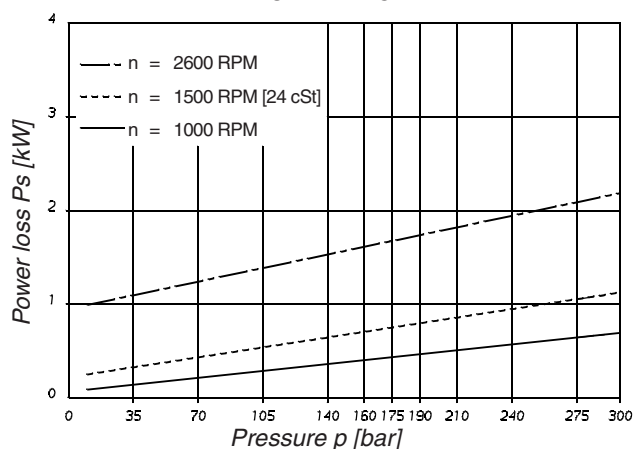

**OUTLET FLOW  
 "P1" CARTRIDGE**

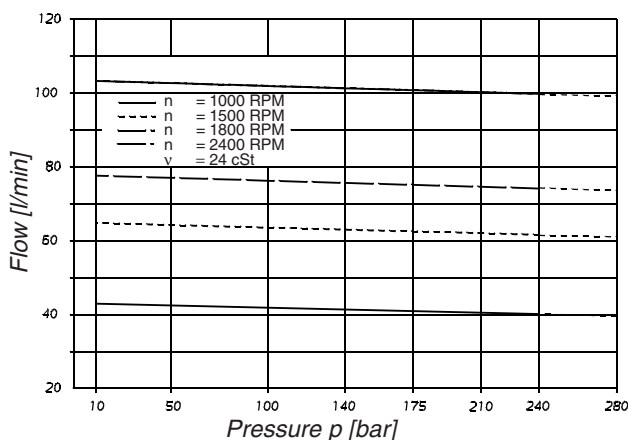

**OVERALL EFFICIENCY - "P1" CARTRIDGE  
 Full displacement**

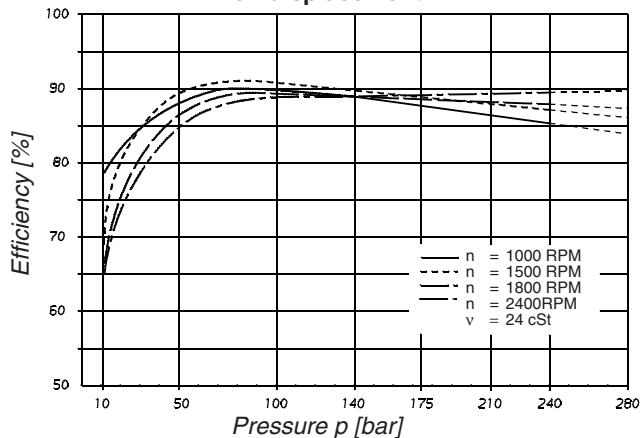

**INPUT HORSEPOWER - "P1" CARTRIDGE  
 Full displacement**

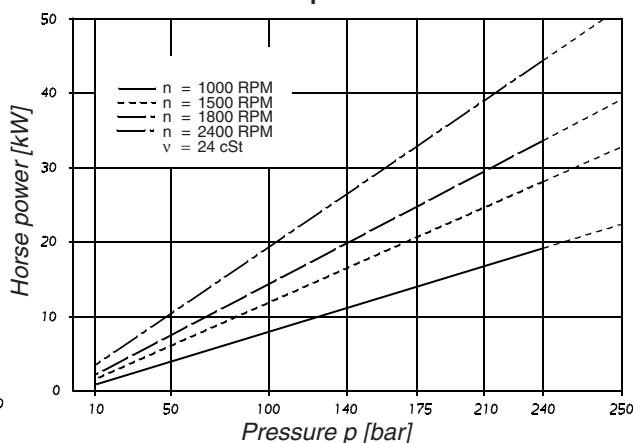

INTERNAL LEAKAGE (TYPICAL)  
"P2" CARTRIDGE

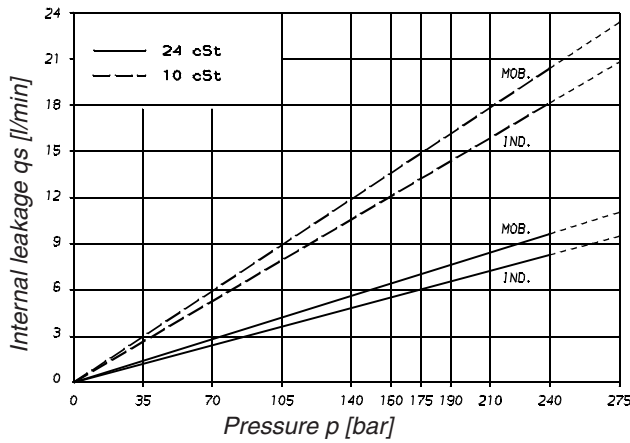

Do not operate pump more than 5 seconds at any speed or viscosity if internal leakage is higher than 50% of theoretical flow.

NOISE LEVEL (TYPICAL)  
T6H20C - B22

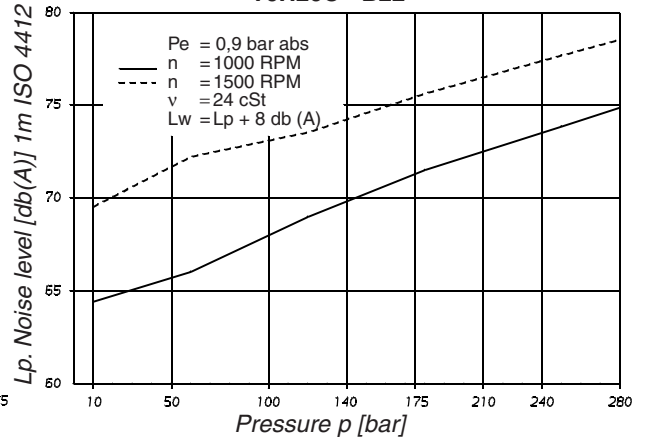

Noise level is given with each cartridge discharging at the pressure noted on the curve (P1 full flow).

HYDROMECHANICAL POWER LOSS (TYPICAL)  
"P2" CARTRIDGE

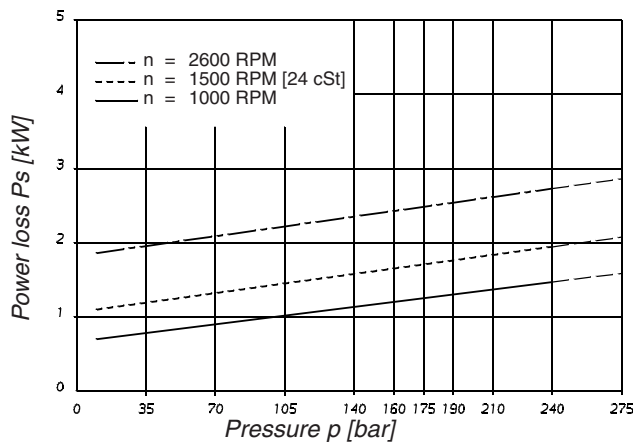

OUTLET FLOW  
"P1" CARTRIDGE

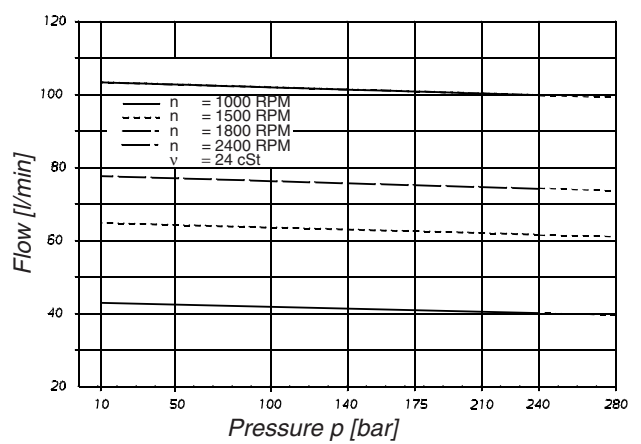

OVERALL EFFICIENCY - "P1" CARTRIDGE  
Full displacement

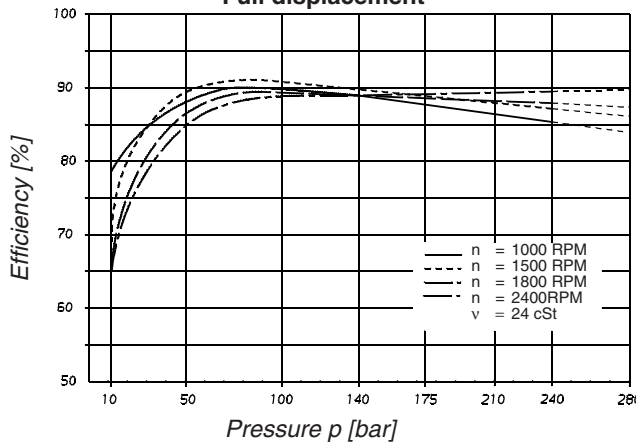

INPUT HORSEPOWER - "P1" CARTRIDGE  
Full displacement

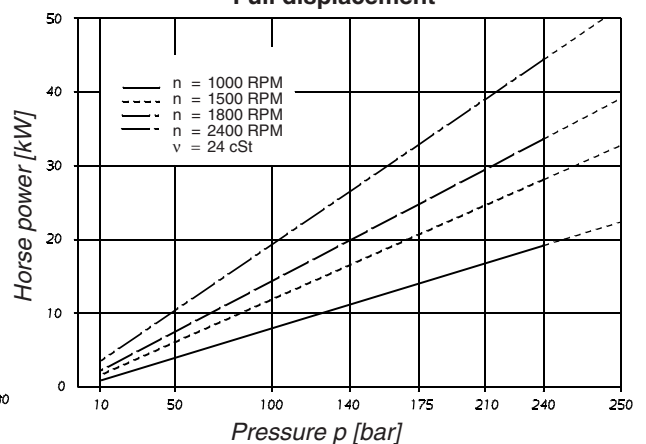



# DTA

Damen Technical Agencies

# ANY PART TIME WHERE

we are doing our parts to keep you moving!

**Damen Technical Agencies B.V.**

Prins Willemstraat 10 - 4791 JR Klundert - The Netherlands

+31 - 168 - 407 144

info@vanepump.eu - vanepump.eu - dta.eu



# DTA

Damen Technical Agencies