



Axial Piston Pumps

Series PVplus
Variable Displacement



parker.com/pmde



ENGINEERING YOUR SUCCESS.



axial piston pump
 variable displacement
 high pressure
 version

size and displacement

rotation

variation

mounting interface

threads code

thru drive code

coupling code

seals

compensator

see next page →

Code	Displacement	Size
063	63 cm ³ /rev	3
080	80 cm ³ /rev	3
092	92 cm ³ /rev	3

Code	Seals	Shaft seal
N	NBR	FKM
V	FKM	FKM
W	NBR	PTFE

Code	Rotation ¹⁾
R	Clockwise
L	Counter clockwise

¹⁾ When looked on shaft

Code	Variation
1	Standard
2	Electronic displacement sensor ²⁾
9	Special adjustment ³⁾

²⁾ not for horse power control

³⁾ requires Kxxxx number

Code	Coupling for thru drive	as single part ⁸⁾
1	Single pump, no coupling	
H	with coupling 25 x 1.5 x 15, DIN 5480	MK-PVBG3K01
J	with coupling 32 x 1.5 x 20, DIN 5480	MK-PVBG3K02
K	with coupling 40 x 1.5 x 25, DIN 5480	MK-PVBG3K03
Y	with coupling SAE A 9T-16/32 DP	MK-PVBG3K11
A	with coupling SAE - 11T-16/32 DP	MK-PVBG3K12
B	with coupling SAE B 13T-16/32 DP	MK-PVBG3K13
C	with coupling SAE B-B 15T-16/32 DP	MK-PVBG3K14
D	with coupling SAE C 14T-12/24 DP	MK-PVBG3K15
E	with coupling SAE C-C 17T-12/24 DP	MK-PVBG3K16
F	with coupling SAE D, E 13T-8/16 DP	MK-PVBG3K17

Code	Mounting interface	Shaft
K	metr. ISO 4-hole flange Ø160 mm	Cylindric, key
L	3019/2 4-hole flange Ø160 mm	Splined, DIN 5480
D	SAE ISO 4-hole flange SAE D	Cylindric, key
E	3019/1 4-hole flange SAE D	Splined, SAE

Code	Thru drive option	
	No adaptor for 2nd pump	
T	Single pump prepared for thru drive	
	with adaptor for 2nd pump as single part ⁸⁾	
A	SAE A, Ø 82.55 mm	MK-PVBG3Axx
B	SAE B, Ø 101.6 mm	MK-PVBG3Bxx
C	SAE C, Ø 127 mm	MK-PVBG3Cxx
D	SAE D, Ø 152.4 mm	MK-PVBG3Dxx
H	metric, Ø 80 mm	MK-PVBG3Hxx
J	metric, Ø 100 mm	MK-PVBG3Jxx
K	metric, Ø 125 mm	MK-PVBG3Kxx
L	metric, Ø 160 mm	MK-PVBG3Lxx

See dimensions for details

⁸⁾ to be ordered separately as single part see page 61.

Code	Port ⁴⁾	Threads ⁵⁾
1	BSPP	metric
3	UNF	UNC
4 ⁶⁾	BSPP	metr. M14
8 ⁷⁾	ISO 6149	metric

⁴⁾ Drain, gage and flushing ports

⁵⁾ All mounting and connecting threads

⁶⁾ For PV063-PV092 only: pressure port 1 1/4" with 4 x M14 instead of 4 x M12

⁷⁾ for mounting interface K and L only

Standard pump is not painted. Black painted pump and ATEX (excludes electronic components) certification (Zone 2) is available as special option. For additional informations please contact Parker Hannifin.

Code			Control options
0	0	1	No control
1	0	0	With cover plate, no control function (fixed displacement pump)
M	M		Standard pressure control
M	R		Remote pressure control
M	F		Load Sensing (flow) control
M	T		Two spool LS control
Control variation			
		C	Standard version, integrated pilot valve ¹⁾
		1	NG6 interface top side for pilot valves
		2	Remote pressure port int. supply , NG6 interface ²⁾
		3	Remote pressure port ext. supply ²⁾
		W	With unloading function, 24VDC solenoid ¹⁾
		K	Prop.-pilot valve type PVACRE...K35 mounted
		Z	Without integrated pilot valve, NG6 interface, for mounting of accessory code PVAC*
		B	Without integrated pilot valve, without NG6 interface ³⁾
		P	MT1 with mounted pilot valve PVAC1P ²⁾

1) not for MT & *Z
2) only for MT
3) not for MT & MM

Horse power / Torque control			
Code		Nominal HP at 1.500 rpm	Nominal torque
G		11 kW	71 Nm
H		15 kW	97 Nm
K		18.5 kW	120 Nm
M		22 kW	142 Nm
S		30 kW	195 Nm
T		37 kW	240 Nm
U		45 kW	290 Nm
W		55 kW	355 Nm
Function			
	L	Horse power control with pressure control ⁴⁾	
	C	Horse power control with load sensing (single spool)	
	Z	Horse power control with two spool LS control	
Control variation			
		C	Standard version, integrated pilot valve ¹⁾
		1	NG 6 interface top side
		W	With unloading function, 24 VDC solenoid
		K	Prop.-pilot valve type PVACRE...K35 mounted
		Z	Without integrated pilot valve, NG6 interface, for mounting of accessory code PVAC* ⁴⁾
		B	Without integrated pilot valve, without NG6 interface ^{1), 4)}

4) control variation Z and B without pressure pilot

Code			Control option
Electro hydraulic control ⁵⁾			
F	D	V	Proportional displacement control, no pressure compensation
U	D		Proportional displacement control, with pressure compensation
Control variation			
		R	pilot operated pressure control, open NG6 interface
		K	pilot operated pressure control, proportional pilot valve type PVACRE...K35 mounted
		M	pilot operated pressure control, pressure sensor and proportional pilot valve type PVACRE...K35 mounted for pressure control and/or power control

5) further info in HY30-3254

Efficiency, power consumption

PV063

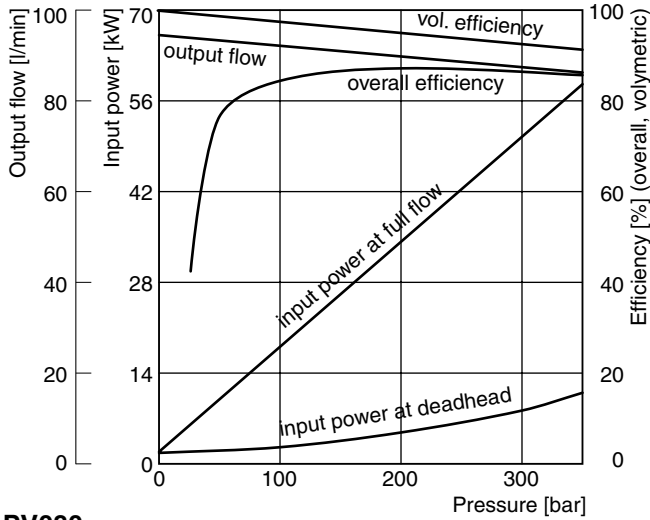

PV080

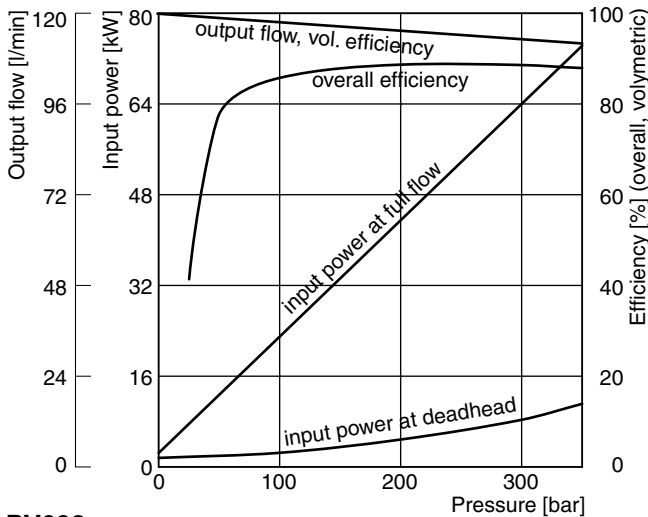

PV092

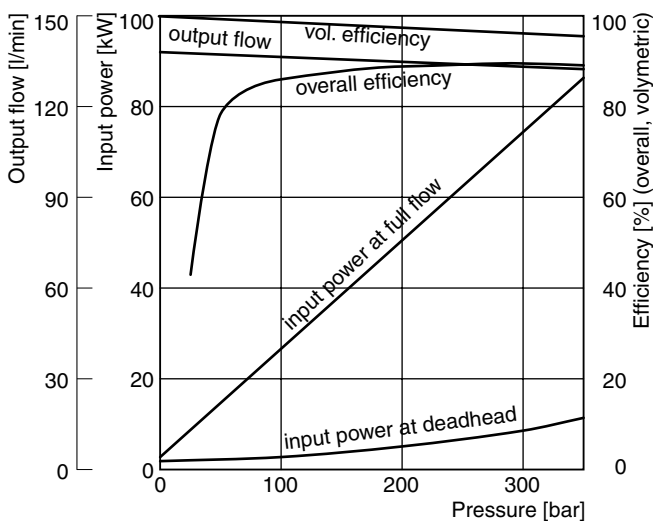

Efficiency and case drain flows PV063, PV080, PV092

The efficiency and power graphs are measured at an input speed of $n = 1500$ rpm, a temperature of $50\text{ }^{\circ}\text{C}$ and a fluid viscosity of $30\text{ mm}^2/\text{s}$.

Case drain flow and compensator control flow leave via the drain port of the pump. To the values shown are to be added 1 to 1.2 l/min, if at pilot operated compensators the control flow of the pressure pilot valve also goes through the pump.

Please note: The values shown below are only valid for static operation. Under dynamic conditions and at rapid compensation of the pump the volume displaced by the servo piston also leaves the case drain port. This dynamic control flow can reach up to 80 l/min! Therefore the case drain line is to lead to the reservoir at full size and without restrictions as short and direct as possible.

Case drain flows PV063-092

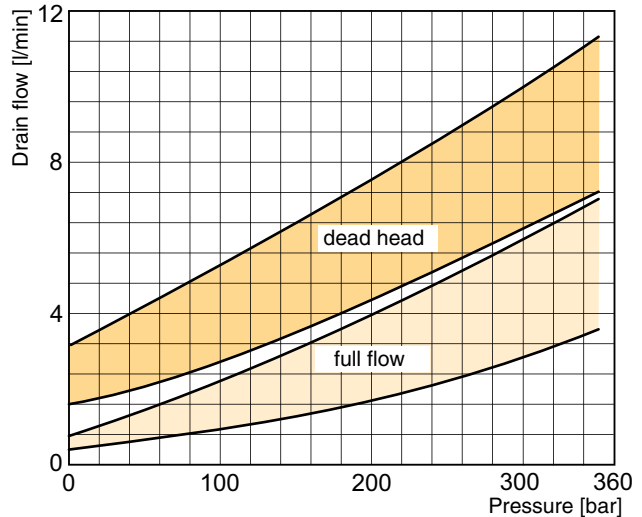

PV 063 - 092 Metric

Mounting interface for horse power pilot or LVDT for displacement feedback

Drain ports L1, L2 and L3; G3/4" optional M27 x 2; ISO 6149-1 (thread option 8) or 1 1/16" - 12 UNF (thread option 3)

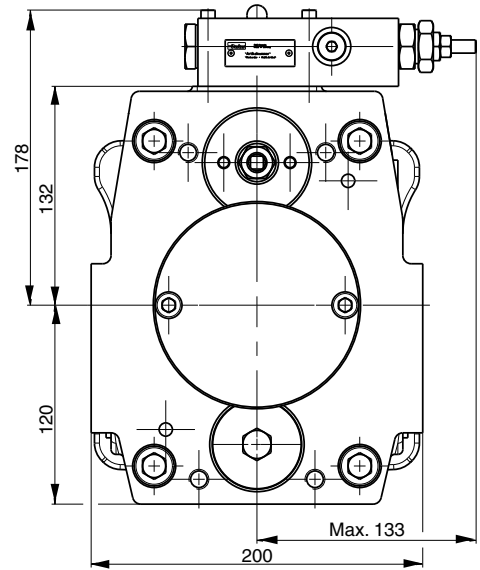
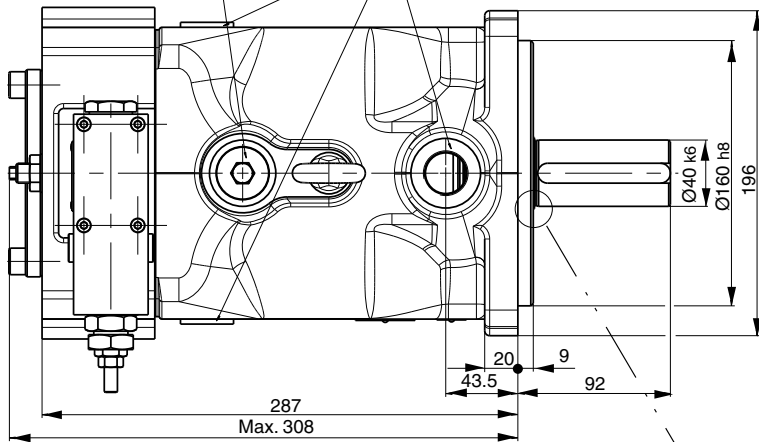

Gage port M; G1/4", optional M12 x 1.5; ISO 6149-1 (thread option 8) or 7/16" - 20 UNF (thread option 3)

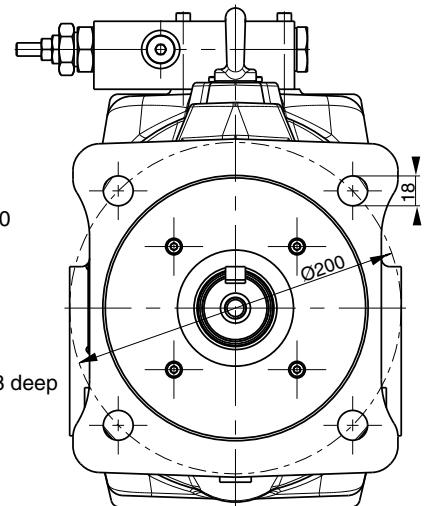
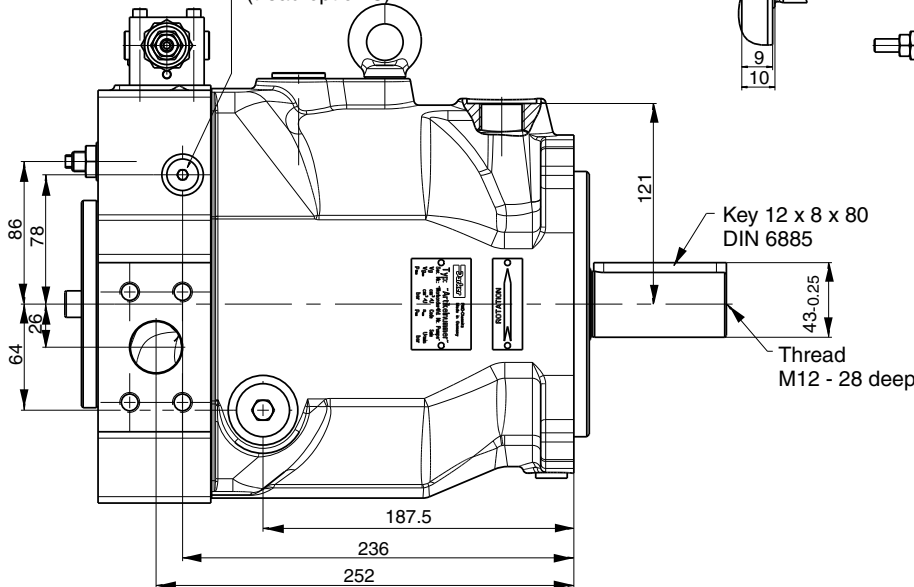

The pump shown above has **Mounting option K** and thru drive variation **T** (prepared for thru drive)

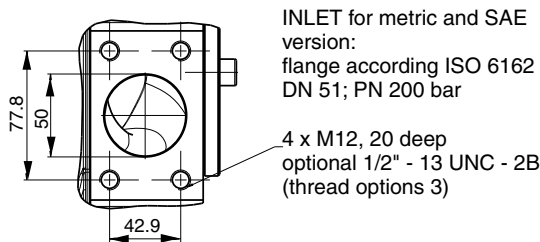

INLET for metric and SAE version: flange according ISO 6162 DN 51; PN 200 bar

4 x M12, 20 deep optional 1/2" - 13 UNC - 2B (thread options 3)

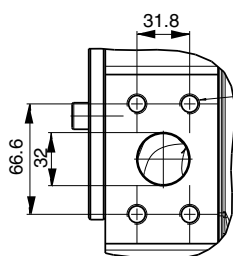

4 x M12, 20 deep optional 1/2" - 13 UNC - 2B (thread options 3) or thread options 4: 4 x M14, 20 deep

OUTLET for metric and SAE version: flange according ISO 6162 DN 32; PN 400 bar

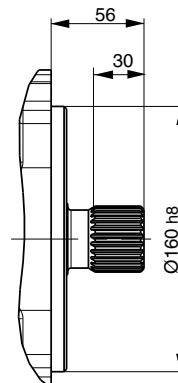

Mounting option L, splined shaft W40 x 1.5 x 25 x 8f DIN 5480

Shown is a clockwise rotating pump with standard pressure compensator. Counter clockwise rotating pumps have inlet, outlet and gage port reversed.

PV 063 - 092 SAE Version

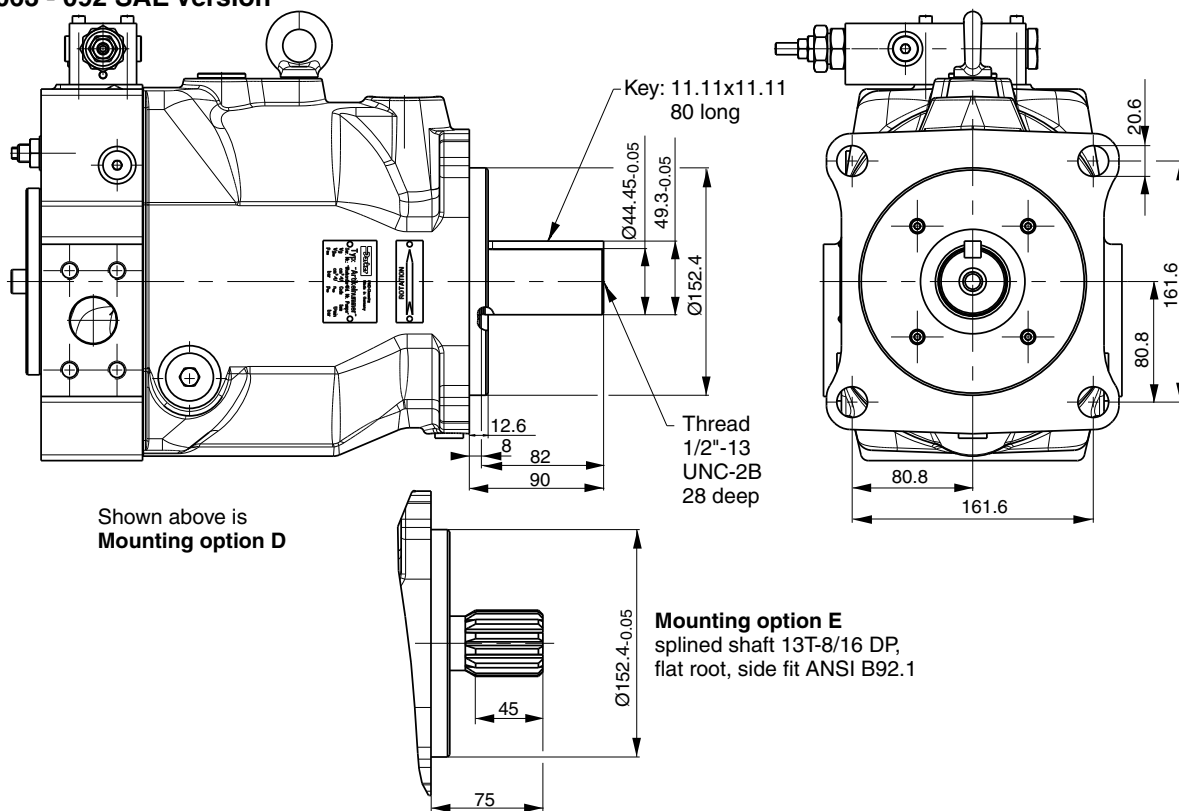

Variation with thru drive

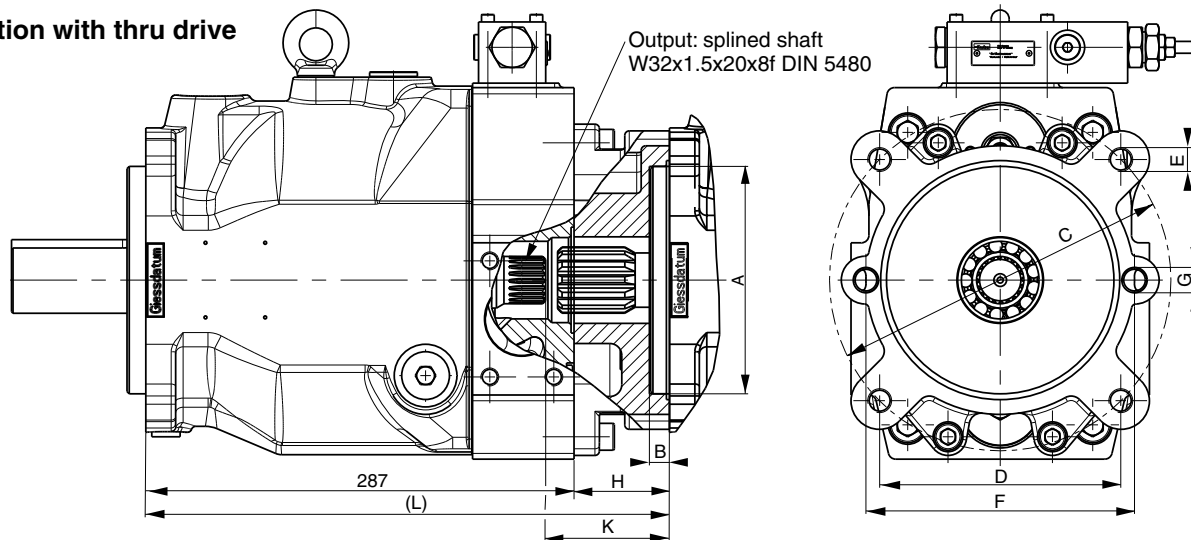

Thru drive adaptors are available with the following dimensions													
Drawing Dimension	A	B	C	D	E		F	G		H	K	L	Remark
					Metr	UNC		Metr	UNC				
Thru drive option													
A	82.55	8	-	-	-	-	106	M10	3/8"-16	39	58	326	SAE A 2-Bolt
B	101.6	11	127	89.8	M12	1/2"-13	146	M12	1/2"-13	39	58	326	SAE B 2/4-Bolt
C	127	13.5	162	114.6	M12	1/2"-13	181	M16	5/8"-11	39	58	326	SAE C 2/4-Bolt
D	152.4	13.5	228.5	161.6	M16	5/8"-11	-	-	-	64	83	351	SAE D 4-Bolt
H	80	8.5	103	72.8	M8	5/16"-18	109	M10	3/8"-16	39	58	326	2/4-Bolt
J	100	10.5	125	88.4	M10	3/8"-16	140	M12	1/2"-13	39	58	326	2/4-Bolt
K	125	10.5	160	113.1	M12	1/2"-13	180	M16	5/8"-11	39	58	326	2/4-Bolt
L	160	13.5	200	141.4	M16	5/8"-11	-	-	-	39	58	326	4-Bolt

Mounting kits for multiple pumps, for second pump option

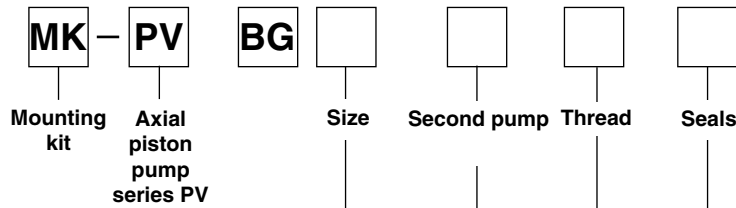

Code	Pump size
1	Pump size 1: PV016 - PV028
2	Pump size 2: PV032 - PV046
3	Pump size 3: PV063 - PV092
4	Pump size 4: PV140 - PV180
5	Pump size 5: PV270 - PV360

Code	Second pump, SAE
T	Prepared for thru drive option (plugged)
Y	SAE AA, diameter 50.8 mm
A	SAE A, diameter 82.55 mm
B	SAE B, diameter 101.6 mm
C	SAE C, diameter 127 mm
D	SAE D, diameter 152.4 mm
E	SAE E, diameter 165.1 mm
Second pump, metric	
G	Diameter 63 mm
H	Diameter 80 mm
J	Diameter 100 mm
K	Diameter 125 mm
L	Diameter 160 mm
M	Diameter 200 mm

Code	Seals
N	NBR
V	FPM

Code	Thread
M	Metric
S	SAE

Kit contains positions 30, 69, 84, 85 and 87, see spare part list

Mounting kits for multiple pumps, couplings

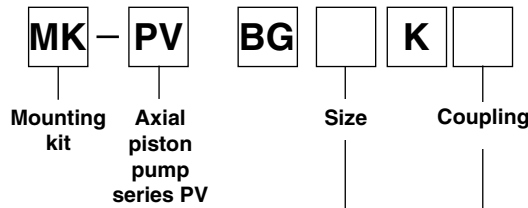

Code	Pump size
1	Pump size 1: PV016 - PV028
2	Pump size 2: PV032 - PV046
3	Pump size 3: PV063 - PV092
4	Pump size 4: PV140 - PV180
5	Pump size 5: PV270 - PV360

Code	Coupling for metric, splined shaft DIN 5480
01	N25 x 1.5 x 15
02	N32 x 1.5 x 20
03	N40 x 1.5 x 25
04	N50 x 2 x 24
05	N60 x 2 x 28
06	N70 x 3 x 22*
Coupling for SAE splined shaft flat root, side fit	
11	SAE A, 9T 16/32
12	SAE-, 11T 16/32
13	SAE B, 13T 16/32
14	SAE B-B, 15T 16/32
15	SAE C, 14T 12/24
16	SAE C-C, 17T 12/24
17	SAE D+E, 13T 8/16
18	SAE F, 15T 8/16
Coupling + adaptor for keyed shaft	
20	Diameter 12 mm
21	Diameter 16 mm
22	Diameter 18 mm

Kit contains positions 1 (and 2 for keyed shaft).

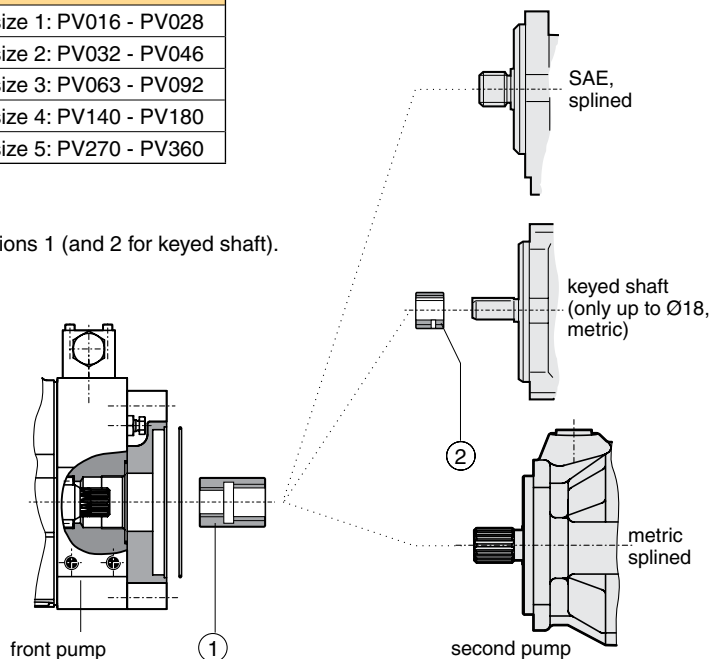

* For PV360 only

Availability of thru drive flange and coupling please check with ordering code options per each pump size, starting at page 6

Multiple Pump Combinations - Maximum Moment

Combinations of multiple pumps might require additional pump support to avoid a too high stress on the front mounting flange. Combinations of two PVplus pumps in the same frame size generally do not need additional support in an industrial application. For combinations of more pumps support is required.

In case of combinations of a PVplus pump with another type of pump it is recommended to calculate the moment for the combination and compare with the maximum moment in table 1 below.

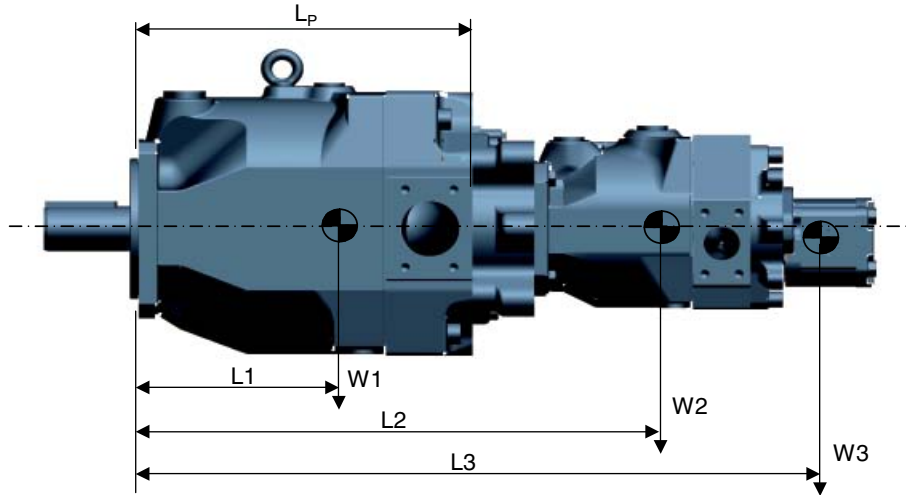

$$\text{Moment } M = (L_1 \cdot W_1 + L_2 \cdot W_2 + L_3 \cdot W_3 + \dots)$$

Note:

If the calculated moment M exceed the maximum moment in table 1 below, additional pump support is needed

Table 1: Maximum Moment and Pump Dimensions

		PV016-PV028	PV032-PV046	PV063-PV092	PV140-PV180	PV270	PV360
Maximum moment ¹⁾	[Nm]	81	151	401	591	1686	1686
Weight W	[N]	186	294	589	883	1687	1766
Distance L1	[mm to C/G]	106	119	178	184	234	238
Distance Lp	[mm]	197.5	227	287	350	472.5	477

1) at dynamic weight acceleration $10g = 98.1 \text{ m/sec}^2$

Table 2 Through Drive Adapter Plate Thickness [mm]

Adapter option ²⁾	PV016-PV028	PV032-PV046	PV063-PV092	PV140-PV180	PV270	PV360
Y	27	-	-	-	-	-
A	27	34	39	65	59	59
B	27	34	39	65	59	59
C	-	49	39	65	59	59
D	-	-	64	65	59	59
E	-	-	-	-	59	59
G	27	34	39	-	-	-
H	27	34	39	65	59	59
J	27	34	39	65	59	59
K	-	34	39	65	59	59
L	-	-	39	65	59	59
M	-	-	-	-	59	59

2) See page 6 to 17 for reference per each frame size.

Maximum allowed transferable torque FRONT							
Shaft code	Shaft type	Transferable torque at FRONT shaft end. [Nm]					
		PV016-028	PV032-046	PV063-092	PV140-180	PV270	PV360
D	SAE - Key	300	650	1850	2150	2150	4750
E	SAE - Spline	320	630	1700	2750	2800	8100*
F	SAE - Key				1200		
G	SAE - Spline				1700		
R	Metric - Key						3750
T	Metric - Spline						8100
K	Metric - Key	280	640	1200	1550	3300	3750
L	Metric - Spline	320	720	1500	3050	5750	8100
Maximum allowed transferable torque REAR							
Max. torque transmission cap. for rear mounted pump		350	520	1100	1550	3150	3250

* DIN5480 splined

Important notice

The max. allowable torque of the individual shaft must not be exceeded. For 2-pump combinations there is no problem because PV series offers 100% thru torque. For 3-pump combinations (and more) the limit torque could be reached or exceeded.

Therefore it is necessary to calculate the resulting input as well as thru drive torque.



WARNING – USER RESPONSIBILITY

FAILURE OR IMPROPER SELECTION OR IMPROPER USE OF THE PRODUCTS DESCRIBED HEREIN OR RELATED ITEMS CAN CAUSE DEATH, PERSONAL INJURY AND PROPERTY DAMAGE.

This document and other information from Parker-Hannifin Corporation, its subsidiaries and authorized distributors provide product or system options for further investigation by users having technical expertise.

The user, through its own analysis and testing, is solely responsible for making the final selection of the system and components and assuring that all performance, endurance, maintenance, safety and warning requirements of the application are met. The user must analyze all aspects of the application, follow applicable industry standards, and follow the information concerning the product in the current product catalog and in any other materials provided from Parker or its subsidiaries or authorized distributors.

To the extent that Parker or its subsidiaries or authorized distributors provide component or system options based upon data or specifications provided by the user, the user is responsible for determining that such data and specifications are suitable and sufficient for all applications and reasonably foreseeable uses of the components or systems.

Offer of Sale

Please contact your Parker representation for a detailed "Offer of Sale".

Parker Worldwide

Europe, Middle East, Africa

AE – United Arab Emirates, Dubai

Tel: +971 4 8127100
parker.me@parker.com

AT – Austria, Wiener Neustadt
Tel: +43 (0)2622 23501-0
parker.austria@parker.com

AT – Eastern Europe, Wiener Neustadt
Tel: +43 (0)2622 23501 900
parker.easteurope@parker.com

AZ – Azerbaijan, Baku
Tel: +994 50 22 33 458
parker.azerbaijan@parker.com

BE/LU – Belgium, Nivelles
Tel: +32 (0)67 280 900
parker.belgium@parker.com

BG – Bulgaria, Sofia
Tel: +359 2 980 1344
parker.bulgaria@parker.com

BY – Belarus, Minsk
Tel: +48 (0)22 573 24 00
parker.poland@parker.com

CH – Switzerland, Etoy
Tel: +41 (0)21 821 87 00
parker.switzerland@parker.com

CZ – Czech Republic, Klecany
Tel: +420 284 083 111
parker.czechrepublic@parker.com

DE – Germany, Kaarst
Tel: +49 (0)2131 4016 0
parker.germany@parker.com

DK – Denmark, Ballerup
Tel: +45 43 56 04 00
parker.denmark@parker.com

ES – Spain, Madrid
Tel: +34 902 330 001
parker.spain@parker.com

FI – Finland, Vantaa
Tel: +358 (0)20 753 2500
parker.finland@parker.com

FR – France, Contamine s/Arve
Tel: +33 (0)4 50 25 80 25
parker.france@parker.com

GR – Greece, Athens
Tel: +30 210 933 6450
parker.greece@parker.com

HU – Hungary, Budaörs
Tel: +36 23 885 470
parker.hungary@parker.com

IE – Ireland, Dublin
Tel: +353 (0)1 466 6370
parker.ireland@parker.com

IT – Italy, Corsico (MI)
Tel: +39 02 45 19 21
parker.italy@parker.com

KZ – Kazakhstan, Almaty
Tel: +7 7273 561 000
parker.easteurope@parker.com

NL – The Netherlands, Oldenzaal
Tel: +31 (0)541 585 000
parker.nl@parker.com

NO – Norway, Asker
Tel: +47 66 75 34 00
parker.norway@parker.com

PL – Poland, Warsaw
Tel: +48 (0)22 573 24 00
parker.poland@parker.com

PT – Portugal
Tel: +351 22 999 7360
parker.portugal@parker.com

RO – Romania, Bucharest
Tel: +40 21 252 1382
parker.romania@parker.com

RU – Russia, Moscow
Tel: +7 495 645-2156
parker.russia@parker.com

SE – Sweden, Spånga
Tel: +46 (0)8 59 79 50 00
parker.sweden@parker.com

SK – Slovakia, Banská Bystrica
Tel: +421 484 162 252
parker.slovakia@parker.com

SL – Slovenia, Novo Mesto
Tel: +386 7 337 6650
parker.slovenia@parker.com

TR – Turkey, Istanbul
Tel: +90 216 4997081
parker.turkey@parker.com

UA – Ukraine, Kiev
Tel: +48 (0)22 573 24 00
parker.poland@parker.com

UK – United Kingdom, Warwick
Tel: +44 (0)1926 317 878
parker.uk@parker.com

ZA – South Africa, Kempton Park
Tel: +27 (0)11 961 0700
parker.southafrica@parker.com

North America

CA – Canada, Milton, Ontario
Tel: +1 905 693 3000

US – USA, Cleveland
(industrial)
Tel: +1 216 896 3000

US – USA, Elk Grove Village
(mobile)
Tel: +1 847 258 6200

Asia Pacific

AU – Australia, Castle Hill
Tel: +61 (0)2-9634 7777

CN – China, Shanghai
Tel: +86 21 2899 5000

HK – Hong Kong
Tel: +852 2428 8008

ID – Indonesia, Tangerang
Tel: +62 21 7588 1906

IN – India, Mumbai
Tel: +91 22 6513 7081-85

JP – Japan, Fujisawa
Tel: +81 (0)4 6635 3050

KR – South Korea, Seoul
Tel: +82 2 559 0400

MY – Malaysia, Shah Alam
Tel: +60 3 7849 0800

NZ – New Zealand, Mt Wellington
Tel: +64 9 574 1744

SG – Singapore
Tel: +65 6887 6300

TH – Thailand, Bangkok
Tel: +662 186 7000

TW – Taiwan, New Taipei City
Tel: +886 2 2298 8987

VN – Vietnam, Ho Chi Minh City
Tel: +84 8 3999 1600

South America

AR – Argentina, Buenos Aires
Tel: +54 3327 44 4129

BR – Brazil, Cachoeirinha RS
Tel: +55 51 3470 9144

CL – Chile, Santiago
Tel: +56 2 623 1216

MX – Mexico, Toluca
Tel: +52 72 2275 4200

Ed. 2016-04-04

EMEA Product Information Centre

Free phone: 00 800 27 27 5374

(from AT, BE, CH, CZ, DE, DK, EE, ES, FI, FR, IE, IL, IS, IT, LU, MT, NL, NO, PL, PT, RU, SE, SK, UK, ZA)

US Product Information Centre

Toll-free number: 1-800-27 27 537

www.parker.com/pmde

Your local authorized Parker distributor

