



DTA

Damen Technical Agencies



Industrial Hydraulic Pumps T67CB, T67CBW

Denison Vane Technology, fixed displacement

Hydraulic Pumps

- Hydraulic Motors
- Hydraulic Valves
- Hydraulic Cylinders
- Hydraulic Filtration
- Hydraulic Accumulators



ENGINEERING YOUR SUCCESS.

We are doing our parts to keep you moving!

DTA your 1 Stop Shop for Hydraulics, Pneumatics and Power Transmissions.

DECLARATION OF CONFORMITY

DTA Hydraulics is a tradename of Damen Technical Agencies BV, supplying hydraulic parts to various industries since 1990. As a Certified Distributor Hydraulics by Parker Hannifin and Authorized Denison Vane Pump Assembler, we guarantee the use of original parts and components. As such we provide you with vane pumps of the same level of quality and warranty conditions as the factory does.

We highly recommend to **use genuine Denison Hydraulics spare parts only** in order to ensure smooth operation and longer service life. Spare parts that we have on stock include pump cartridge kits, shaft and bearing assemblies, seal kits and non-wearing parts of both the T6 and T7 series vane pumps.



**ALL VANE PUMPS SUPPLIED OR REPAIRED BY
DTA HYDRAULICS HAVE BEEN ASSEMBLED ACCORDING
TO THE LATEST FACTORY SPECIFICATIONS WITH
BRAND NEW AND GENUINE DENISON HYDRAULICS PARTS**

We are able to provide you a large variety of options of the original Parker Denison single, double, and triple vane pumps. We can build any customized vane pump from our stock of genuine parts. You can now easily configure that vane pump yourself with the Denison Hydraulics Vane Pump Configurator.

vanepump.eu/vanepumps

Use advanced search to filter results based on configurable options and select any of the 25,000 vane pumps that are listed in our online catalogue. Most of the models are available from stock and ready for shipment to any place in the world instantly. We can supply **Any part, Anytime, Anywhere!**



Model No. T67CB W - 010 - B10 - 1 R 00 - A 1 M1 - ..

Series - SAE B 2 bolts
 J744 mounting flange
Severe duty shaft

Displacement P1
 Volumetric displacement (ml/rev.)
 003 = 10,8 017 = 58,3
 005 = 17,2 020 = 63,8
 006 = 21,3 022 = 70,3
 008 = 26,4 025 = 79,3
 010 = 34,1 028 = 88,8
 012 = 37,1 031 = 100,0
 014 = 46,0

Displacement P2
 Volumetric displacement (ml/rev.)
 B02 = 5,8 B09 = 28,0
 B03 = 9,8 B10 = 31,8
 B04 = 12,8 B11 = 35,0
 B05 = 15,9 B12 = 41,0
 B06 = 19,8 B14 = 45,0
 B07 = 22,5 B15 = 50,0
 B08 = 24,9

Type of shaft **Severe duty shaft (T67CW only)**
 1 = keyed (non SAE) 2 = keyed (SAE BB)
 3 = splined (SAE BB) 15 teeth
 5 = splined (SAE B) 13 teeth

Modifications

Mounting w/connection variables
 11 = 4 bolts SAE flange
 (J518) UNC thread
 M1 = 4 bolts SAE flange
 (J518) Metric thread

Seal class
 1 = S1 BUNA N - 0,7 bar max. (for mineral oil)
 4 = S4 EPDM - 7 bar max. (for fire resistant fluids)
 5 = S5 VITON® - 7 bar max. (for mineral oil and fire resistant fluids)

Design letter

Porting combination(see page 72)
 00 = standard

Direction of rotation (shaft end view)
 R = Clockwise
 L = Counter-clockwise

INTERNAL LEAKAGE (TYPICAL)

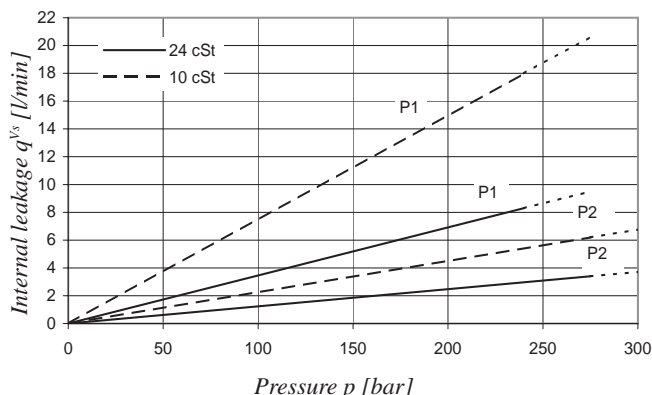

Do not operate pump more than 5 seconds at any speed or viscosity if internal leakage is higher than 50% of theoretical flow.
 Total leakage is the sum of each section loss under its respective operating conditions.

NOISE LEVEL (TYPICAL) - T67CB - 014 - B03

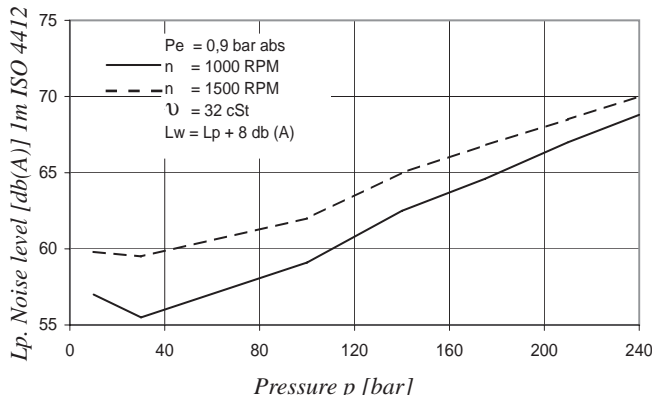

Double pump noise level is given with both stages discharging at the pressure value indicated on the curve.

POWER LOSS HYDROMECHANICAL (TYPICAL)

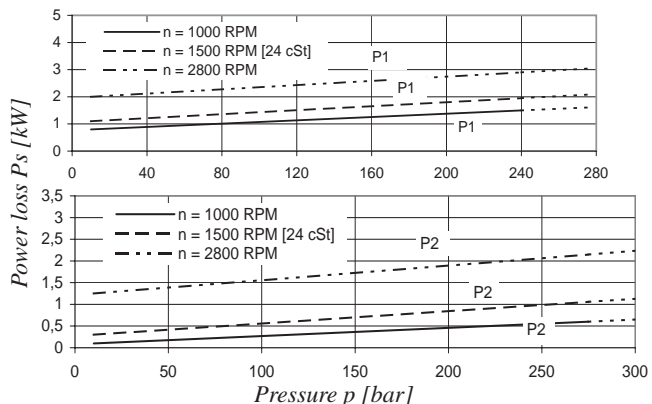

Total hydromechanical power loss is the sum of each section loss under its respective operating conditions.

PERMISSIBLE RADIAL LOAD

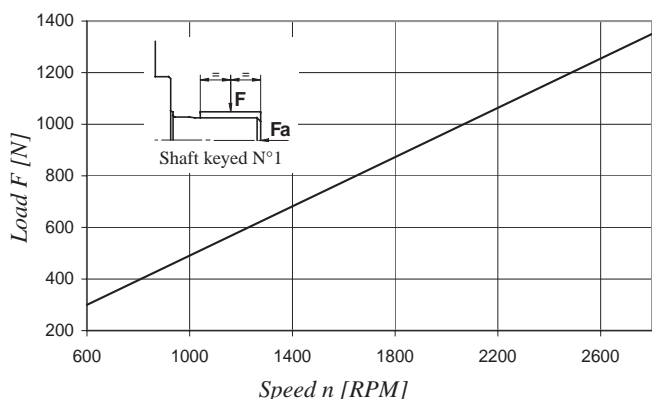

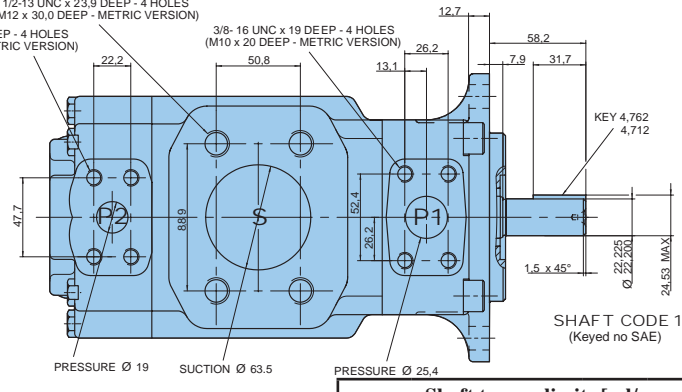
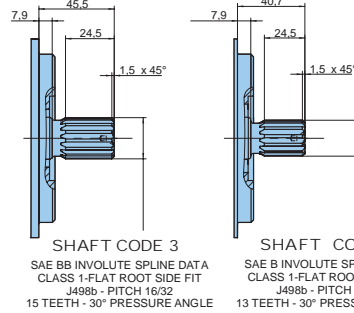
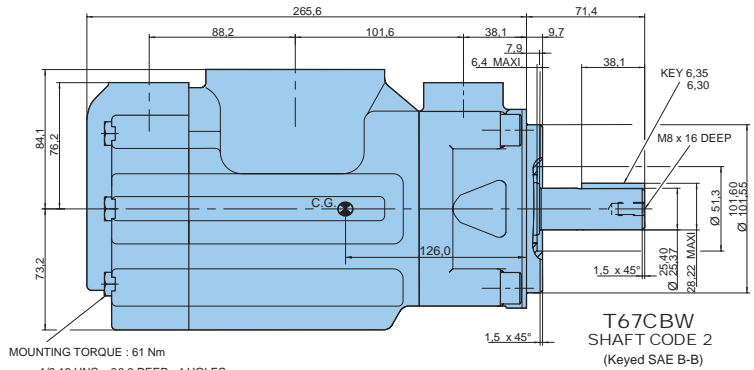
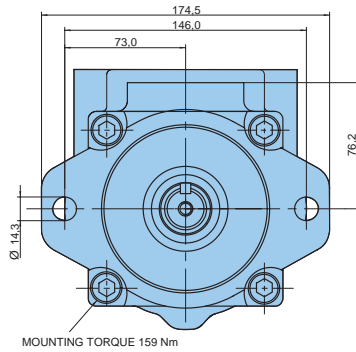

Shaft torque limits [ml/rev. x bar]			
Shaft	Vi x p max.	Shaft	Vi x p max.
1	14300	3	32670
2	21420	5	20600

OPERATING CHARACTERISTICS - TYPICAL [24 cSt]

Pressure port	Series	Vi Volumetric displacement	Flow q _v [l/min] & n = 1500 RPM			Input power P [kW] & n = 1500 RPM		
			p = 0 bar	p = 140 bar	p = 275 bar	p = 7 bar	p = 140 bar	p = 275 bar
P1	003	10,8 ml/rev	16,2	11,2	*	1,3	5,3	*
	005	17,2 ml/rev	25,8	20,8	16,1	1,4	7,5	13,9
	006	21,3 ml/rev	31,9	26,9	22,2	1,5	8,9	16,8
	008	26,4 ml/rev	39,6	34,6	29,9	1,6	10,7	20,3
	010	34,1 ml/rev	51,1	46,1	41,4	1,7	13,4	25,6
	012	37,1 ml/rev	55,6	50,6	45,9	1,7	14,4	27,6
	014	46,0 ml/rev	69,0	64,0	59,3	1,9	17,6	33,7
	017	58,3 ml/rev	87,4	82,4	77,7	2,1	21,9	42,2
	020	63,8 ml/rev	95,7	90,7	86,0	2,2	23,8	46,0
	022	70,3 ml/rev	105,4	100,4	95,7	2,3	26,1	50,4
	025	79,3 ml/rev	118,9	113,9	109,2	2,5	29,2	56,6
028	88,8 ml/rev	133,2	128,2	125,8 ¹⁾	2,8	32,7	48,5 ¹⁾	
031	100,0 ml/rev	150,0	145,0	142,6 ¹⁾	2,8	36,5	54,4 ¹⁾	
P2			p = 0 bar	p = 140 bar	p = 300 bar	p = 7 bar	p = 140 bar	p = 300 bar
	B02	5,8 ml/rev	8,7	7,0	5,1	0,5	2,6	5,1
	B03	9,8 ml/rev	14,7	13,0	11,1	0,6	4,0	8,1
	B04	12,8 ml/rev	19,2	17,5	15,6	0,6	5,0	10,4
	B05	15,9 ml/rev	23,9	22,2	20,2	0,7	6,1	12,7
	B06	19,8 ml/rev	29,7	28,0	26,1	0,7	7,5	15,6
	B07	22,5 ml/rev	33,7	32,0	30,2	0,8	8,5	17,6
	B08	24,9 ml/rev	37,4	35,7	33,7	0,8	9,3	19,5
	B09	28,0 ml/rev	42,0	40,3	38,4	0,9	10,4	21,8
	B10	31,8 ml/rev	47,7	46,0	44,1	0,9	11,7	26,2
	B11	35,0 ml/rev	52,5	50,8	48,9	1,0	12,8	27,0
	B12	41,0 ml/rev	61,5	59,8	57,9	1,1	14,9	31,5
	B14	45,0 ml/rev	67,5	65,8	63,9	1,2	16,3	34,5
	B15	50,0 ml/rev	75,0	73,3	71,6 ²⁾	1,3	18,1	35,7 ²⁾

* We do not recommend to use the size 003 in P1 at 275 bar & 1500 RPM as the internal is over 50% of theoretical flow.

¹⁾ 028 - 031 = 210 bar max.int. ²⁾ B15 = 280 bar max.int.



DTA

Damen Technical Agencies

OVER 25 YEARS

we are doing our parts to keep you moving!

DTA your ONE Stop Shop

for Hydraulics, Pneumatics and Power Transmissions

Damen Technical Agencies B.V.

Prins Willemstraat 10 - 4791 JR Klundert - The Netherlands

+31 - 168 - 407 144

info@vanepump.eu - vanepump.eu - dta.eu



DTA

Damen Technical Agencies